

Index

Heat Load Selections	Conditions of quick selections Cold Rooms 50mm Cold Rooms 100mm Freezer Rooms 100mm Freezer Rooms 150mm
	Milk Tank Selections
	L'Unite Condensing Units & Accessories Blue Line Condensing Units & Accessories
	Under Bar Unit Selections Equivalent Units
Equivalentents	Evaporator equivalents Condenser Equivalentents
TEV's	Quick Select & Equivalentents
Domestic Refrigeration	Compressor Selections & Equivalentents Thermostat Wiring & Equivalentents
General	Metric Imperial Conversions Fraction Conversions Quick Temp Conversions
Refrigerants	Cross Reference Guide What to expect after change of Refrigerant

Conditions for Quick Selection Rooms

Rooms are calculated at a 32°C Ambient (most rooms are installed indoors)
--

Heat Loads include a 10% safety factor

Cold Rooms

Holding Only

Product enters at room temperature or below +2°C

Average Usage

35Kg of product per m³ in at +20°C or below

Heavy Usage

70Kg of product per m³ in at +20°C or below

For Glass Doors add 500 Watts per door

Freezer Rooms

Holding Only

Product enters at room temperature or below -20°C
--

Average usage

35Kg of product per m³ in at -5°C or below
--

Heavy Usage

35Kg of product per m³ in at +10°C or below

For Glass Doors add 650 Watts per door

Cold Room +2°C 50mm

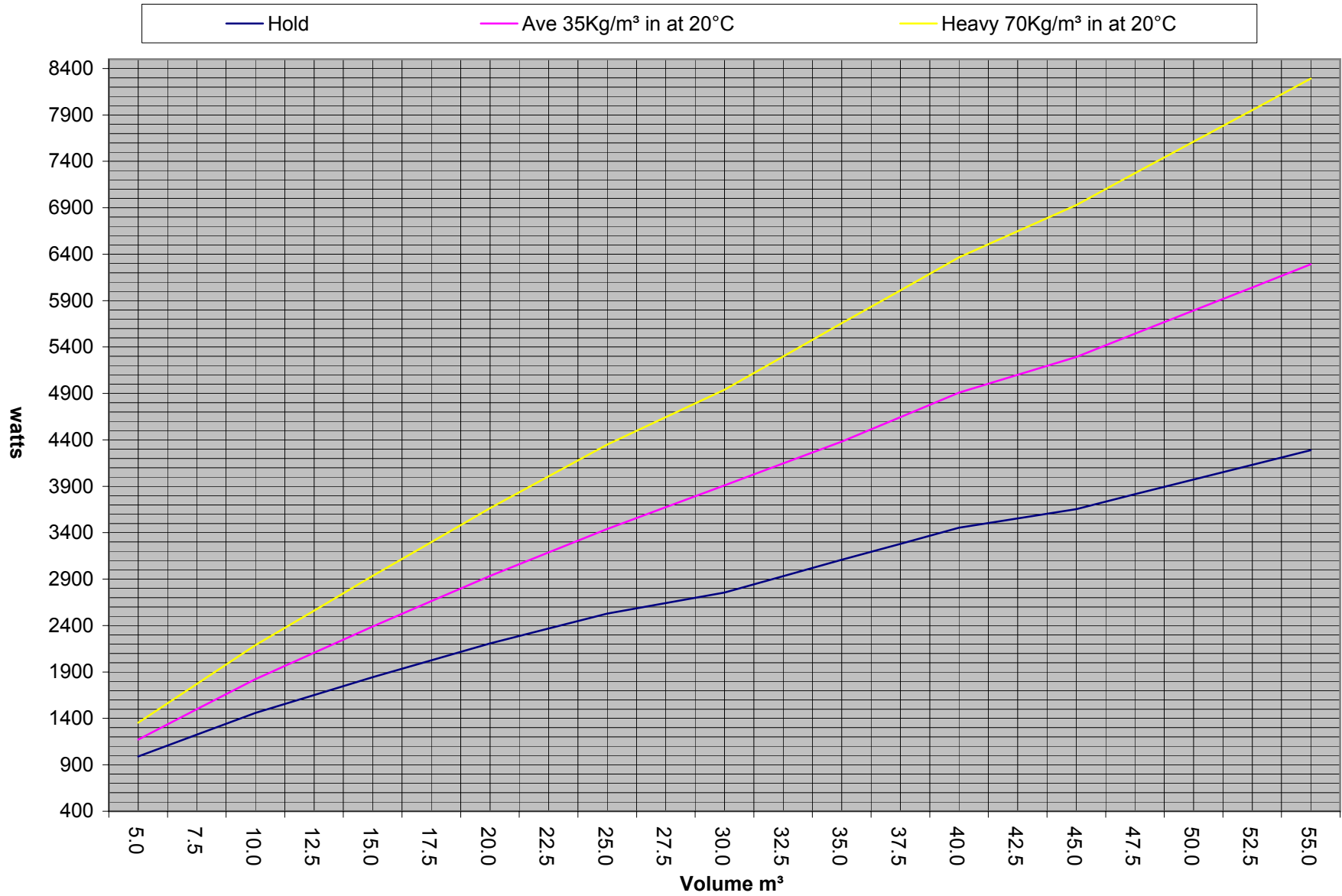

Cold Room +2°C 50mm

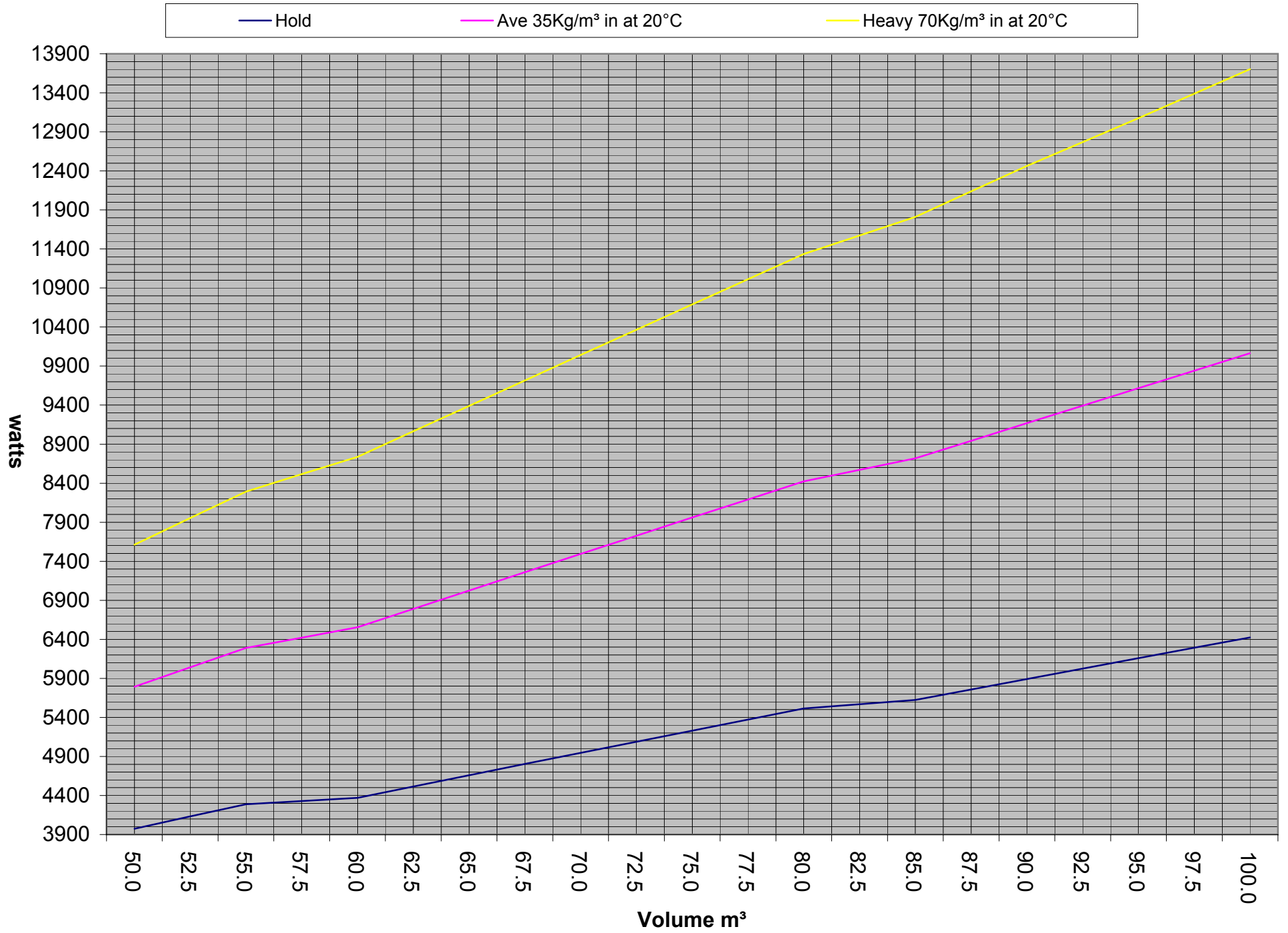

Cold Room +2°C 100mm

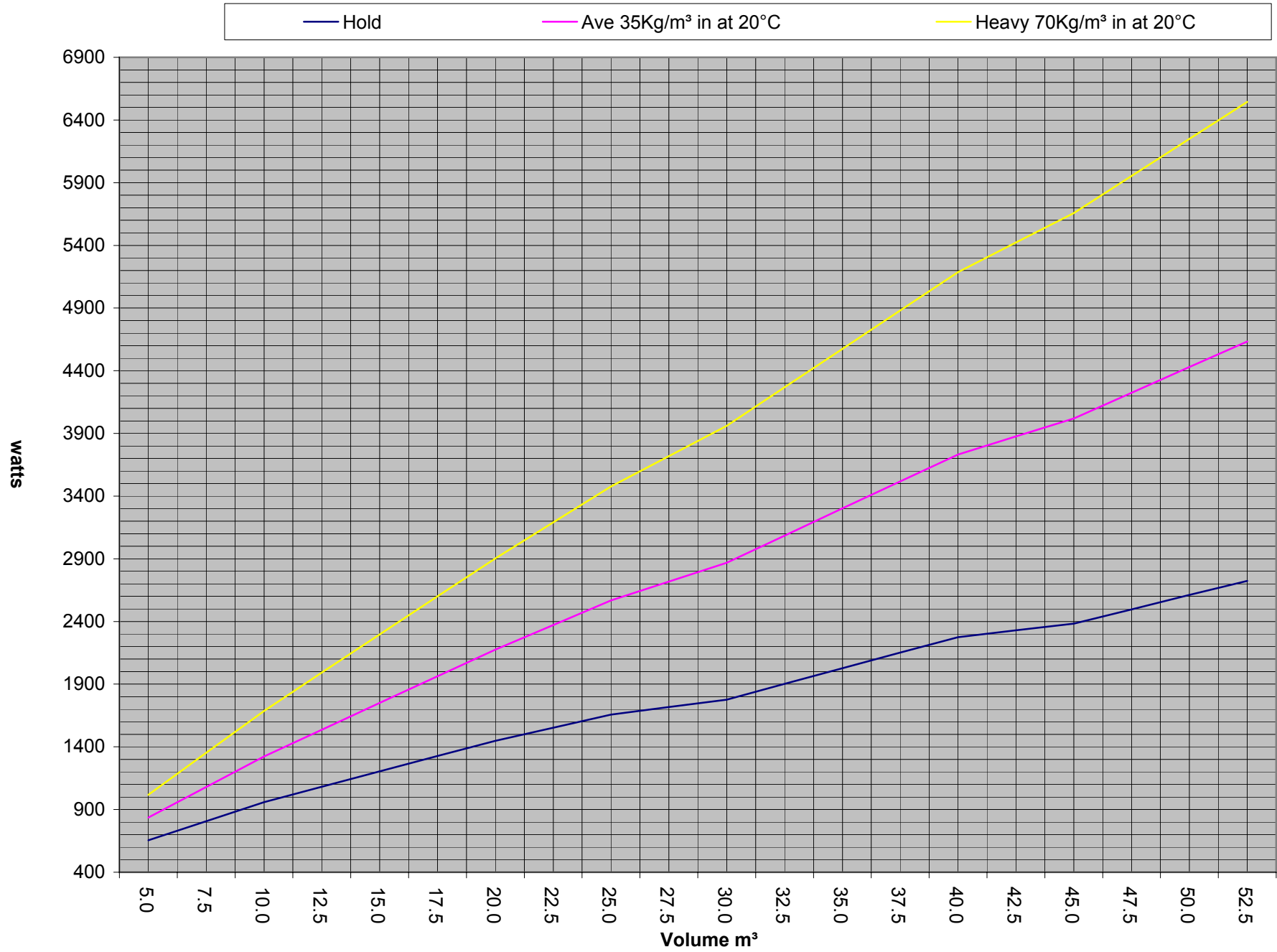

Cold Room +2°C 100mm

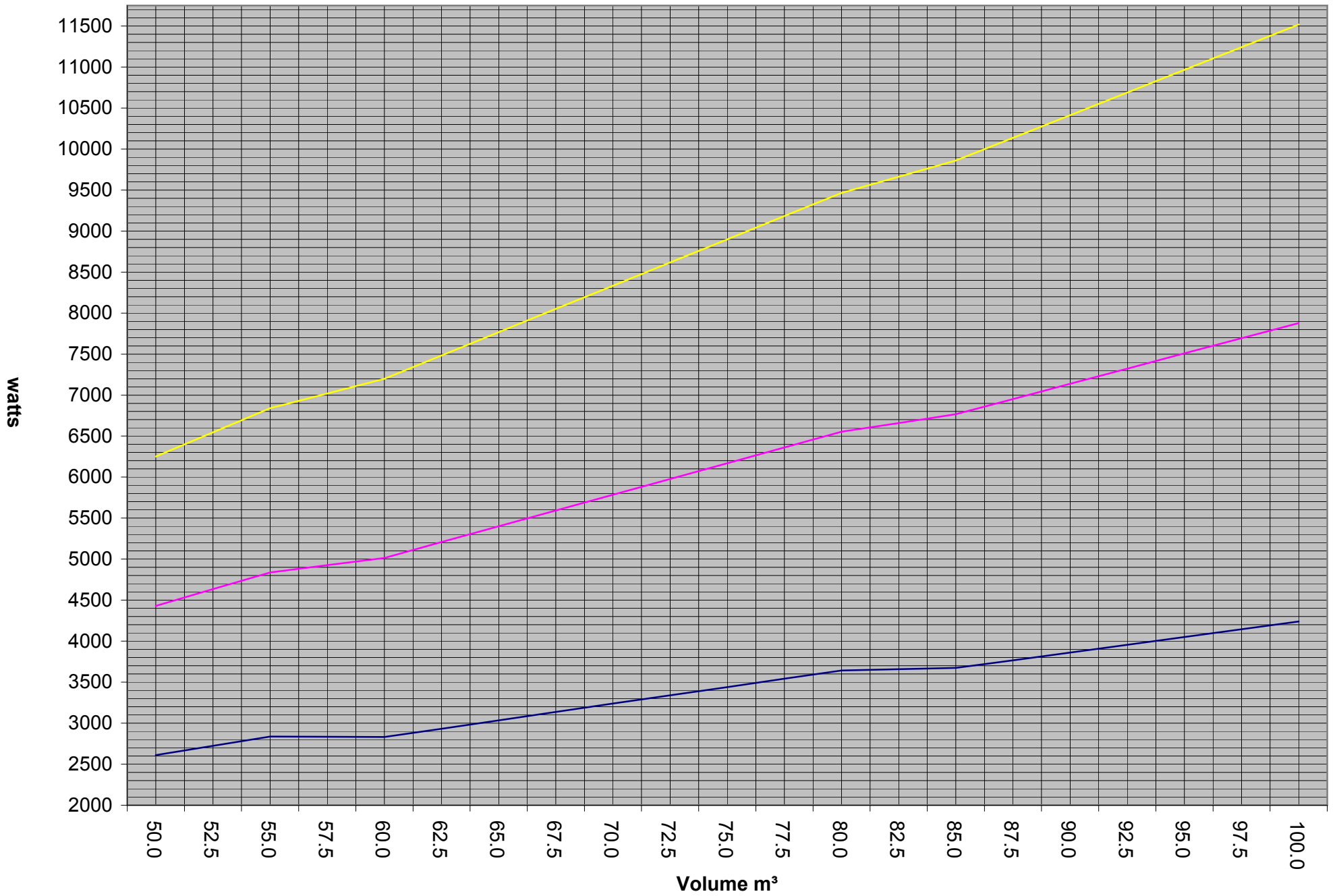

Freezer Room -18°C 100mm

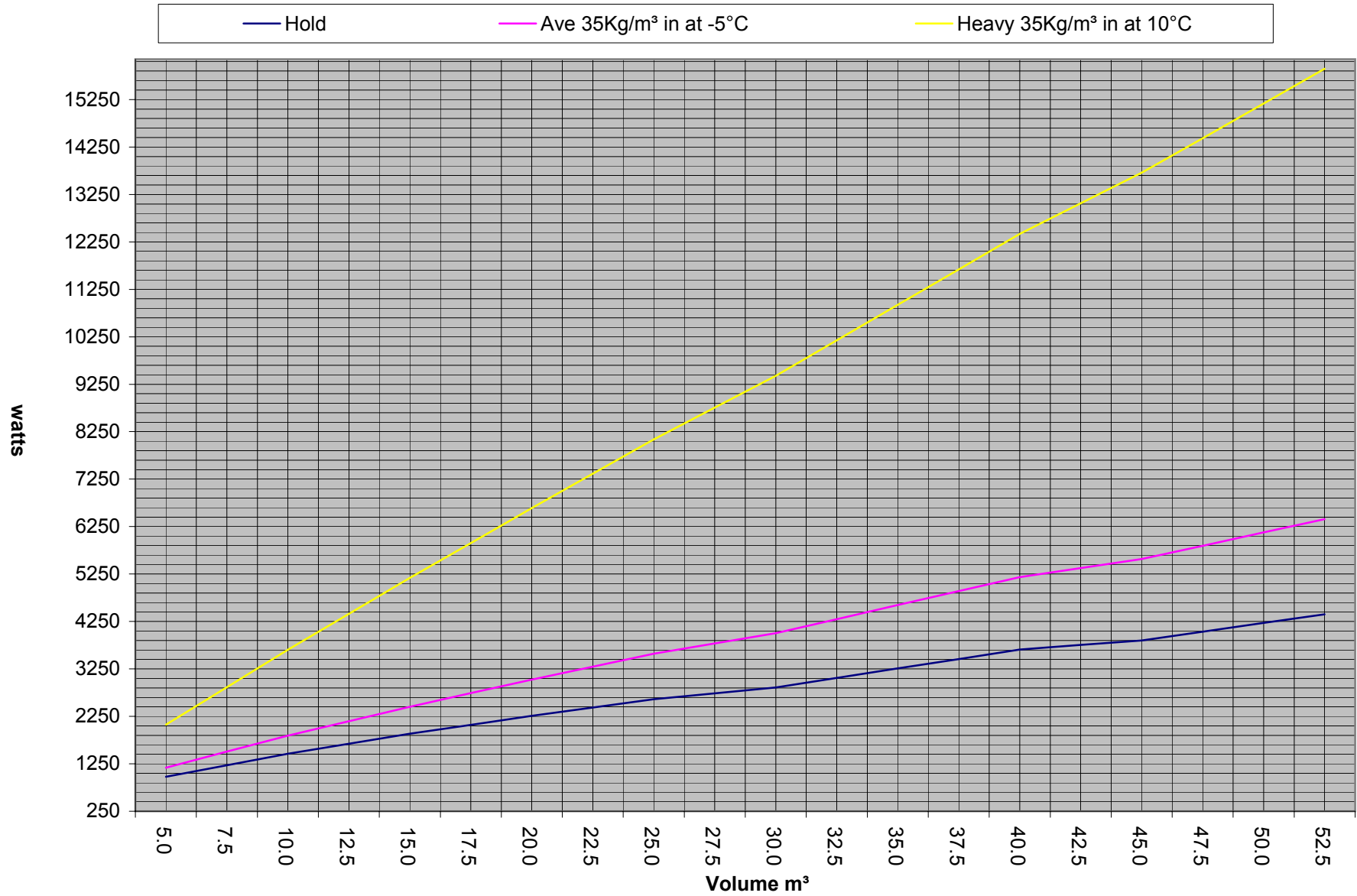

Freezer Room -18°C 100mm

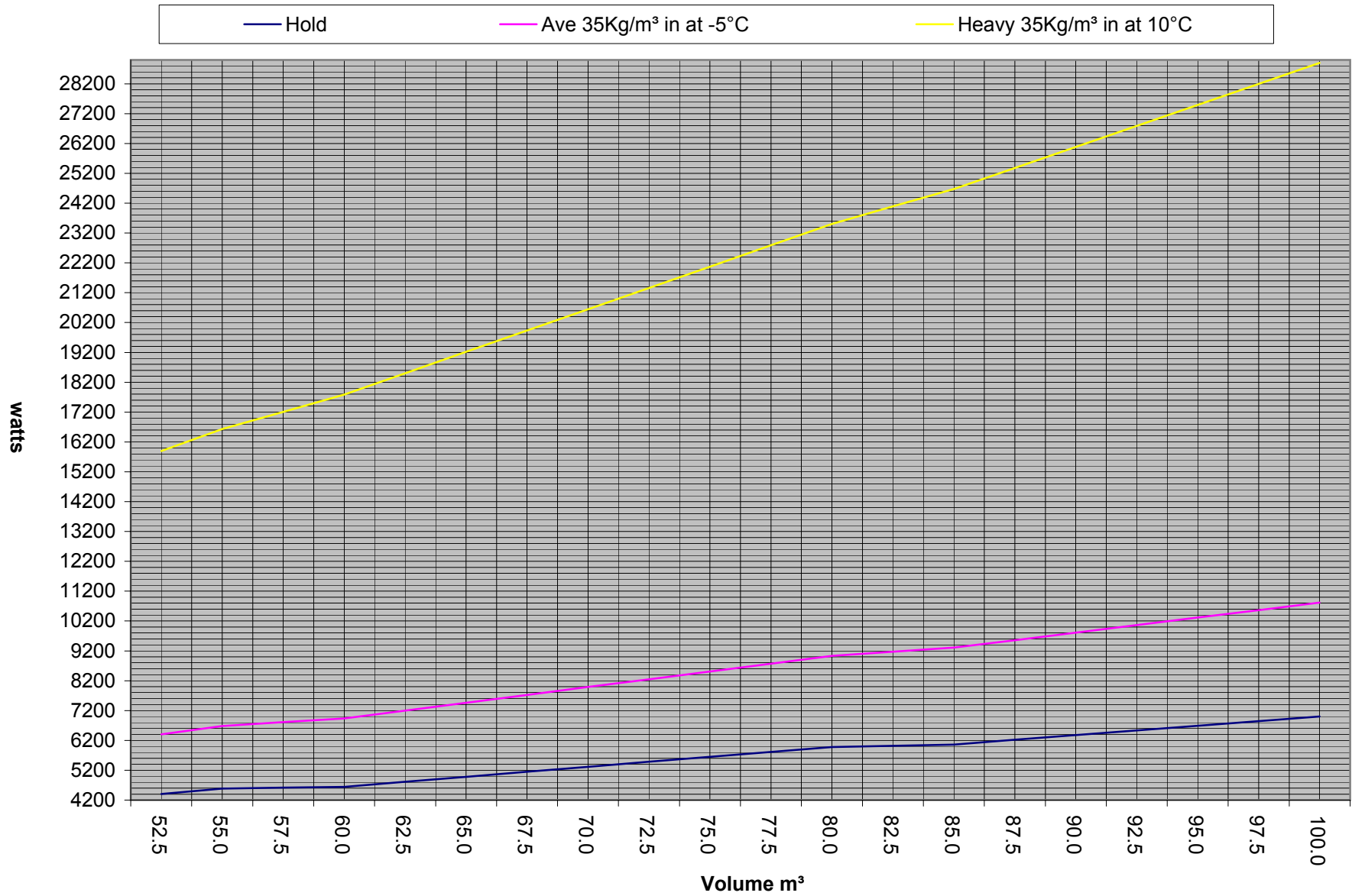

Freezer Room -18°C 150mm

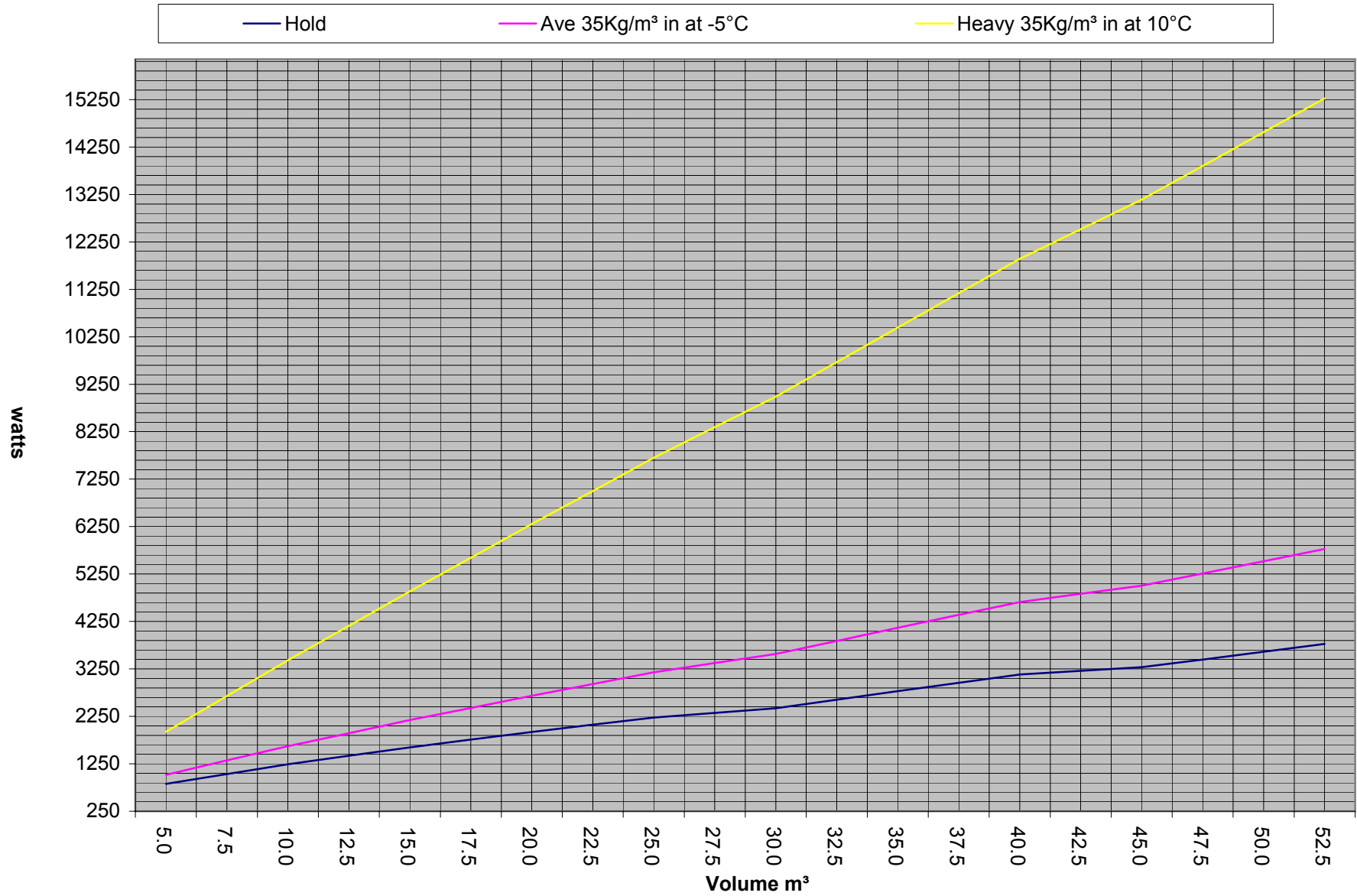

Freezer Room -18°C 150mm

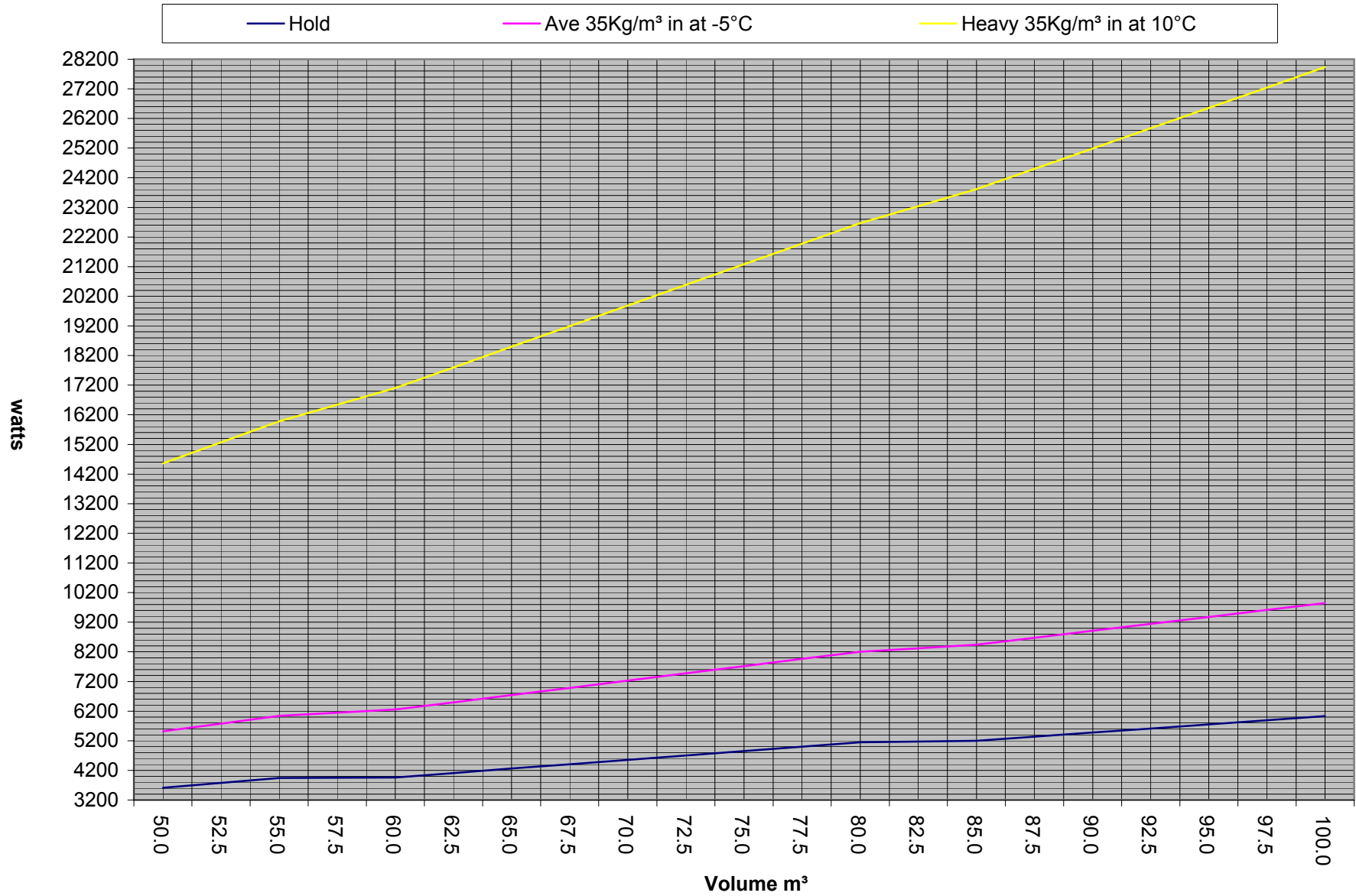

Milk Tank Capacities

Alfa Laval	
Tank Size (Litres)	Cap Req (Watts) @ 0°C
650 EAD	3200
1200 EAD	5815
1800 EAD	7560
2400 EAD	8140
4000 EAD	14580
5000 EAD	18225
6000 EAD	21870
7000 EAD	25520

Mueller (NCD)	
Tank Size (Litres)	Cap Req (Watts) @ -3°C
380 EAD	1230
570 EAD	1815
760 EAD	2860
1200 EAD	3870
1500 EAD	4840
1500 ED	9680
2300 ED	7330
2300 ED	14660
3800 EAD	12450
3800 ED	24900
4750 EAD	15240
4750 ED	30480

Milkrite	
Tank Size (Litres)	Cap Req (Watts) @ -5°C
500 EAD	1860
750 EAD	2790
1000 EAD	3720
1400 EAD	5210
1600 EAD	5950
2400 EAD	8930
5000 EAD	18600
6000 EAD	22320

For Unknown Tanks, Use the formulas below

Every Day (ED)

Litres X 6 X 3.97 = BTU's Required at -5°C Te

Every Alternate Day (EAD)

Litres X 3 X 3.97 = BTU's Required at -5°C Te

R22 MEDIUM TEMP.

L'Unite Model	Reco S/C	suct	capacity	cond	5K TD			7K TD			TXV	orifice
AEZ9440EHR	46472	-3.0	712	44.2	RONDO240	RCT240H					TEX2	00
		-5.0	665	43.5				RONDO240	RCT240H		TEX2	00
CAE9450EHR	46692	-3.0	893	46.1	RONDO340	RCT350H					TEX2	00
		-5.0	826	45.0				RONDO240	RCT240H		TEX2	00
CAE9460TMHR	46700	-3.0	1046	48.0	NST350	RONDO400	RCT350H				TEX2	00
		-5.0	974	47.0				RONDO240	RCT240H		TEX2	00
CAJ9480TMHR	47500	-3.0	1474	47.1	NST450	RONDO500	RCT540H				TEX2	01
		-5.0	1390	46.1				NST350	RONDO400	RCT350	TEX2	01
CAJ9510TMHR	47509	-3.0	1757	48.3	NST600	RONDO700	RCT750H				TEX2	01
		-5.0	1640	47.2				NST450	RONDO440		TEX2	01
CAJ9513TMHR	47510	-3.0	2144	48.5	NST750	RCT750H					TEX2	01
		-5.0	2010	47.1				NST600	RONDO500	RCT540H	TEX2	01
CAJ4517EHR	47536	-3.0	2676	45.4	NST900	RONDO900	RCT1000H				TEX2	01
		-5.0	2490	44.5				NST700	RONDO700	RCT750H	TEX2	01
TAJ4517THR	45864	-3.0	2676	45.4	NST900	RONDO900	RCT1000H				TEX2	01
		-5.0	2490	44.5				NST700	RONDO700	RCT750H	TEX2	01
FH4522FHR	47048	-3.0	3625	46.4	NST1300	RONDO1300					TEX2	02
		-5.0	3372	45.3				NST900	RONDO900	RCT1000H	TEX2	02
TFH4522FHR	47054	-3.0	3625	46.4	NST1300	RONDO1300					TEX2	02
		-5.0	3372	45.3				NST900	RONDO900	RCT1000H	TEX2	02
FH4524FHR	47049	-3.0	3809	48.5	NST1300						TEX2	02
		-5.0	3530	47.2				NST900	RONDO1100	RCT1000H	TEX2	02
TFH4524FHR	47070	-3.0	3809	48.5	NST1300						TEX2	02
		-5.0	3530	47.2				NST900	RONDO1100	RCT1000H	TEX2	02
FH4531FHR	47094	-3.0	5572	43.7	NST2000						TEX2	03
		-5.0	5210	42.8				NST1600			TEX2	03
TFH4531FHR	47110	-3.0	5572	43.7	NST2000						TEX2	03
		-5.0	5210	42.8				NST1600			TEX2	03

Blue*Line MBP R22

Blue Line	Reco S/C	capacity	suct	ambient		5K TD			7K TD	
CMH018	40002	2811	-3.0	34	NST900	RONDO1100	RCT1000H			
		2536	-5.0	34				NST700	RONDO700	RCT750H
CMH022	40006	3812	-3.0	34	NST1300					
		3485	-5.0	34				NST900	RONDO900	RCT1000H
CMH028	40012	5489	-3.0	34	NST1800					
		5063	-5.0	34				NST1300	RONDO1300	
CMH032	40018	5873	-3.0	34	NST2000					
		5414	-5.0	34				NST1600		
CMH036	40024	6890	-3.0	34	NST2200					
		6391	-5.0	34				NST1800		
CMH040	40028	7625	-3.0	34	NST2600					
		7031	-5.0	34				NST1800		
CMH044	40042	7916	-3.0	34	NST3050					
		7297	-5.0	34				NST1800		
CMH050	40047	8684	-3.0	34	NST3050					
		7954	-5.0	34				NST2000		
CMH056	40051	9978	-3.0	34	NST3200	2 x NST1800				
		9201	-5.0	34				NST2200		
CMH064	40053	11468	-3.0	34	SST4360	2 x NST2000	UC540N			
		10544	-5.0	34				NST2600	2 x NST1300	
CMH072	40054	12872	-3.0	34	SST5080	2 x NST2200	UC660N			
		11887	-5.0	34				NST3050	2 x NST1600	
CMH080	40057	14460	-3.0	34	UC750N	2 x SST2640	2 x NST2600			
		13369	-5.0	34				NST3200	2 x NST1600	
CMH100	40065	17402	-3.0	34	UC890N	2 x SST3270	2 x NST3050			
		15988	-5.0	34				SST4360	2 x NST2600	
CMH125	40071	22314	-3.0	34	UC1120N	2 x SST4360	3 x NST2600			
		20572	-5.0	34				UC750N	2 x SST2640	2 x NST3050
CMH144	40075	25040	-3.0	34	UC1320N	2 x UC610N	3 x NST3050			
		23132	-5.0	34				UC890N	2 x SST3270	2 x NST3200
CMH160	40079	28050	-3.0	34	UC1320N	2 x UC660N	3 x NST3200			
		25851	-5.0	34				UC890N	2 x SST3270	2 x NST3200

Blue*Line MBP R22

Blue Line	Reco S/C	TXV	orifice	sol v/v	15m liq	15m suct	armaflex	stat
CMH018	40002	TEX2	01	EVR6 3/8"	3/8"	1/2"	1/2" x 1/2"	UT72
CMH022	40006	TEX2	01	EVR6 3/8"	3/8"	1/2"	1/2" x 1/2"	UT72
CMH028	40012	TEX2	02	EVR6 3/8"	3/8"	5/8"	5/8" x 1/2"	UT72
CMH032	40018	TEX2	02	EVR6 3/8"	3/8"	5/8"	5/8" x 1/2"	UT72
CMH036	40024	TEX2	03	EVR6 1/2"	1/2"	3/4"	3/4" x 1/2"	UT72
CMH040	40028	TEX2	03	EVR6 1/2"	1/2"	3/4"	3/4" x 1/2"	UT72
CMH044	40042	TEX2	03	EVR6 1/2"	1/2"	3/4"	3/4" x 1/2"	UT72
CMH050	40047	TEX2	03	EVR6 1/2"	1/2"	3/4"	3/4" x 1/2"	UT72
CMH056	40051	TEX2	03	EVR6 1/2"	1/2"	7/8"	7/8" x 1/2"	UT72
CMH064	40053	TEX2	03	EVR6 1/2"	1/2"	7/8"	7/8" x 1/2"	UT72
CMH072	40054	TEX2	03	EVR6 1/2"	1/2"	7/8"	7/8" x 1/2"	UT72
CMH080	40057	TEX2	03	EVR6 1/2"	1/2"	7/8"	7/8" x 1/2"	UT72
CMH100	40065	TEX2	04	EVR6 1/2"	1/2"	7/8"	7/8" x 1/2"	UT72
CMH125	40071	TEX2	04	EVR6 1/2"	1/2"	7/8"	7/8" x 1/2"	UT72
CMH144	40075	TEX2	04	EVR6 1/2"	1/2"	7/8"	7/8" x 1/2"	UT72
CMH160	40079	TEX2	04	EVR6 1/2"	1/2"	7/8"	7/8" x 1/2"	UT72

R404A LOW TEMP.

L'Unite Model	Reco S/C	capacity	suct	cond	ambient	5K TD			TXV	orifice
CAJ2428ZBR	47448	655	-23.3	43.1	32	RCT240L	RONDO240	RDD250L	TES2	00
CAJ2432ZBR		768	-23.3	44.6	32	RCT350L	RONDO340	RDD300L	TES2	01
CAJ2446ZBR	47464	1241	-23.3	41.6	32	NLT450	RCT540L	RDD500L	TES2	01
FH2480ZBR	47027	2217	-23.3	46.3	32	NLT900	RCT1000L	RDD900L	TES2	03
TFH2480ZBR	47026	2217	-23.3	46.3	32	NLT900	RCT1000L	RDD900L	TES2	03
FH2511ZBR	47030	2883	-23.3	45.6	32	NLT1100			TES2	03
TFH2511ZBR	47034	2883	-23.3	45.6	32	NLT1100			TES2	03
TAG2516ZBR		4307	-23.3	44.0	32	NLT1800			TES2	05
TAG2522ZBR		5357	-23.3	44.7	32	NLT2000			TES2	06

L'Unite Model	Reco S/C	sol v/v	drier	s/glass	10m liq	10m suct	armaflex	stat	HP	LP	Dual HP/LP
CAJ2428ZBR	47448	EVR3 1/4"	DCL032S	SGN 6S	1/4"	1/2"	1/2" x 3/4"	UT72	KP5	KP1	KP15
CAJ2432ZBR		EVR3 1/4"	DCL032S	SGN 6S	1/4"	5/8"	5/8" x 3/4"	UT72	KP5	KP1	KP15
CAJ2446ZBR	47464	EVR6 3/8"	DCL033S	SGN 10S	3/8"	5/8"	5/8" x 3/4"	UT72	KP5	KP1	KP15
FH2480ZBR	47027	EVR6 3/8"	DCL033S	SGN 10S	3/8"	7/8"	7/8" x 3/4"	UT72	KP5	KP1	KP15
TFH2480ZBR	47026	EVR6 3/8"	DCL033S	SGN 10S	3/8"	7/8"	7/8" x 3/4"	UT72	KP5	KP1	KP15
FH2511ZBR	47030	EVR6 3/8"	DCL033S	SGN 10S	3/8"	7/8"	7/8" x 3/4"	UT72	KP5	KP1	KP15
TFH2511ZBR	47034	EVR6 3/8"	DCL033S	SGN 10S	3/8"	7/8"	7/8" x 3/4"	UT72	KP5	KP1	KP15
TAG2516ZBR		EVR6 1/2"	DCL084S	SGN 12S	1/2"	7/8"	7/8" x 3/4"	UT72	KP5	KP1	KP15
TAG2522ZBR		EVR6 1/2"	DCL084S	SGN 12S	1/2"	7/8"	7/8" x 3/4"	UT72	KP5	KP1	KP15

It is recommended that an oil separator & Suction Accumulator is fitted on low Temp Units

Unit for under bar fridges

Doors	R22 L'Unite	L'Unite	Capacity	R22 Sicom	Sicom	Capacity	Evap 1	Evap 2	Evap 3	TEV	L/L
1		AEZ4430E	521		AE9415ES	525	RDD100	Rondo 140	RCT175	TX2-0X	1/4"
1 1/2		AEZ4430E	521		AE9415ES	525	RDD100	Rondo 140	RCT175	TX2-0X	1/4"
2		AEZ4430E	521		AE9415ES	525	RDD150	Rondo 140	RCT175	TX2-0X	1/4"
2 1/2		AEZ4430E	521		AE9415ES	525	RDD150	Rondo 140	RCT175	TX2-0X	1/4"
3		AEZ9440T	710		AE9422ES	712	RDD200	Rondo 240	RCT175	TX2-00	1/4"
3 1/2		AEZ9440T	710		AE9422ES	712	RDD200	Rondo 240	RCT175	TX2-00	1/4"
4		CAE9450T	858		AE9430ES	849	RDD250	Rondo 240	RCT240	TX2-00	1/4"
4 1/2		CAE9450T	858		AE9430ES	849	RDD250	Rondo 240	RCT240	TX2-00	1/4"
5		CAE9460T	1098		AE9440ES	1075	RDD300	Rondo 340	RCT350	TX2-00	1/4"
5 1/2	CAE9460T	1098	AE9440ES	1075	RDD300	Rondo 340	RCT350	TX2-00	1/4"		
6	CAE9460T	1098	AE9440ES	1075	RDD300	Rondo 340	RCT350	TX2-00	1/4"		

Unit for under bar fridges

Doors	R134a L'Unite	Model	Capacity	R134a Sicom	Sicom	Capacity	Evap 1	Evap 2	Evap 3	TEV	L/L
1		AEZ4430Y	529		AE4430YS	489	RDD100	Rondo 140	RCT160	TN2-00	1/4"
1 1/2		AEZ4430Y	529		AE4430YS	489	RDD100	Rondo 140	RCT160	TN2-00	1/4"
2		AEZ4430Y	529		AE4430YS	489	RDD150	Rondo 140	RCT160	TN2-00	1/4"
2 1/2		AEZ4430Y	529		AE4430YS	489	RDD150	Rondo 140	RCT160	TN2-00	1/4"
3		CAE4440Y	687		AE4440YS	646	RDD200	Rondo 240	RCT175	TN2-00	1/4"
3 1/2		CAE4440Y	687		AE4440YS	646	RDD200	Rondo 240	RCT175	TN2-00	1/4"
4		CAJ4452Y	886		AE4448YS	754	RDD250	Rondo 240	RCT240	TN2-01	1/4"
4 1/2		CAJ4452Y	886		AE4448YS	754	RDD250	Rondo 240	RCT240	TN2-01	1/4"
5		CAJ4461Y	1048		AKM19YS	1111	RDD300	Rondo 340	RCT350	TN2-02	1/4"
5 1/2	CAJ4461Y	1048	AKM19YS	1111	RDD300	Rondo 340	RCT350	TN2-03	1/4"		
6	CAJ4461Y	1048	AKM19YS	1111	RDD300	Rondo 340	RCT350	TN2-04	1/4"		

Capacities based at -5°C Te & 45°C Tc

Compares to Danfoss Hermetic Compressors 220V for R 134a, R 22, R 404A & R 507									
Refrigerant application	L'unite	Displacement	Danfoss	Displacement	Application	Code	Sicom	Displacement	Nomimal HP
R134a -35/-10°C	AZ1320Y	2.95	TLS3FT	3.13	LBP	102G4324			1/12
	AZ1330Y	3.6	TLS4FT	3.86	LBP	102G4424	THB1345YS		1/10
	AZ1335Y	4							
	AZ1339Y	5	TLS5FT	5.08	LBP	102G4524	THB1355YS		1/6
	AEZ1365Y	8.9	NL9FT	8.35	LBP	105G6827	THC1365YS		1/5
	AEZ1380Y	9.4	NL10FT	10.10	LBP	105G6829	TW1390YS		1/4
	AE1410Y	12.05	NL11F	11.15	LBP	105G6900	TP1410YS		1/3
R134a -35/15°C	AE4414Y	4	TL4G	3.86	LBP-HBP	102G4452			1/8
	AEZ4425Y	7.55	FR7.5G	6.93	LBP-HBP	103G6680	AE4448YS	7.57	1/5
			FR8.5G	7.95	LBP-HBP	103G6870			
	AEZ4430Y	8.85	FR10G	9.05	LBP-HBP	103G6880	AE4430Y	8.85	1/4
			SC10G	10.29	LBP-HBP	104G8000			1/3
	CAE4440Y	12.05	SC12G	12.87	LBP-HBP	104G8240	AE4448YS	12.04	+1/3
	CAJ4452Y	15.20	SC15G	15.28	LBP-HBP	104G8520	AKM16YS	16.00	3/8
CAJ4461Y	18.30	SC18G	17.69	LBP-HBP	104G8820	AKM19YS	18.80	1/2	
CAE4476Y	21.75	SC21G	20.95	LBP-HBP	104G8140			5/8	
R22 -15/10°C	CAE9450T	9.5	SC10D	10.3	HBP	104L2529	AE9430ES	8.85	3/8
	CAE9460T	11.3	SC12D	12.9	HBP	104L2694	AE9440ES	12.04	1/2
	CAJ9480T	15.2	SC15D	15.3	HBP	104L2859			5/8
R404A/R507 -45/-5°C			FR8.5CL	7.95	LBP	103U2890			1/4
			SC10CL	10.29	LBP	104L2523			1/3
	CAE2417Z	11.3	SC12CL	12.87	LBP	104L2623	AE2415ZS	11.3	3/8
	CAJ2428Z	15.2	SC15CL	15.28	LBP	104L2853			1/2
	CAJ2432Z	18.3	SC18CL	17.69	LBP	104L2123	AKL19ZS	18.8	5/8
		SC21CL	20.95	LBP	104L2322			3/4	

Medium Temp Range			
Model	W @ -4°C 6Td	Model	W @ -4°C 6Td
		SU34H	1080
NST350	1374		
		SU51H	1460
NST450	1656		
		SU64H	1714
		SU81H	1905
NST600	2046	SU72H	2095
NST700	2320		
NST750	2656		
		SU101H	3048
NST900	3140		
		SU131H	3430
NST1100	3865	SU156H	3620
NST1300	4428	SU142H	4382
		SU196H	4826
NST1600	5340		
		SU240H	5778
		SU201H	5905
NST1800	6283		
		SU271H	7048
NST2000	7254		
NST2200	7738	SU322H	7684
NST2600	8896		
		SU395H	9906
NST3050	10254		
NST3200	11739		

Low Temp Range			
Model	W @ -24°C 6Td	Model	W @ -24°C 6Td
		SU34L	1003
NLT350	1184		
		SU51L	1357
NLT450	1426		
		SU64L	1593
NLT600	1763	SU81L	1770
NLT700	1998	SU72L	1947
NLT750	2288		
NLT900	2706	SU101L	2832
		SU131L	3186
NLT1100	3330	SU156L	3363
NLT1300	3815	SU142L	4071
		SU196L	4484
NLT1600	4601		
		SU240L	5369
NLT1800	5413	SU201L	5487
NLT2000	6251		
		SU271L	6459
NLT2200	6668		
		SU322L	7139
NLT2600	7665		
NLT3050	8836		
		SU395L	9204
NLT3200	10115		

Condensor Bases				
Model	W @ 15Td		Model	W @ 15Td
RBA530/1	5300			
RBA580/1	5800		HAC500	5750
			HAC600	5930
RBA680/1	6800			
RBA695/1	6950		HAC700	7080
RBA890/1	8900		HAC800	8130
RBA1070/1	10700		HAC1100	10370
RBA1220/1	12200		HAC1250	12470
RBA1350/1	13500			
RBA1380/1	13800		HAC1350	13670
RBA1530/1	15300		HAC1600	15320
RBA1810/1	18100			
			HAC1700	19190
RBA2130/1	21300		HAC1900	21630
RBA2360/1	23600		HAC2100	23150
RBA2570/1	25700			
RBA2760/1	27600		HAC2600	28160
RBA1190/2	11900			
RBA1470/2	14700			
RBA1640/2	16400			
RBA1710/2	17100		HAC1630	17040
RBA2140/2	21400			
RBA2560/2	25600			
RBA2860/2	28600		HAC2850	27340
RBA3210/2	32100		HAC3000	33900
RBA3720/2	37200		HAC3500	38100
RBA3960/2	39600			
RBA4150/2	41500			
RBA4350/2	43500			
RBA4530/2	45300		HAC4100	46730
RBA5010/2	50100			
RBA5240/2	52400		HAC4600	52190
RBA5560/2	55600		HAC4900	55410
RBA5770/2	57700			
RBA6110/3	61100			
RBA6630/3	66300			
RBA7350/3	73500		HAC6700	73550
RBA7530/3	75300		HAC7100	77840
RBA7850/3	78500			
RBA8290/3	82900			
RBA8620/3	86200			
			HAC9100	99770

QUICK SELECTION FOR EXPANSION VALVES

Refrigerant	Valve Type	Pressure Equalisation	Connection Solder	Flare X	Code no		Components with flare connections	
					Range N -40 to +10°C		Without MOP	With MOP
					Without MOP	With MOP	Without MOP	With MOP
R 22	TX2	INT	3/8fl in x1/2 sol out		068Z3281	068Z3287	068Z3206	068Z3208
	TEX2	EXT	3/8fl in x1/2 sol out		068Z3284	068Z3290	068Z3209	068Z3211
R134A	TN2	INT	3/8fl in x1/2 sol out		068Z3383	068Z3387	068Z3346	068Z3347
	TEN2	EXT	3/8fl in x1/2 sol out		068Z3385	068Z3389	068Z3348	068Z3349
R404A/	TS2	INT	3/8fl in x1/2 sol out		068Z3414	068Z3416	068Z3400	068Z3402
R 507	TES2	EXT	3/8fl in x1/2 sol out		068Z3415	068Z3417	068Z3403	068Z3405

Orifice assembly Range N; -40to+10°C

Orifice	Rated capacity in tons			Rated capacity in KW			Code no
	R 22	R134A	R404A	R 22	R134A	R404A	
OX	0.2	0.1	0.1	0.7	0.5	0.4	068-2002
O0	0.4	0.2	0.2	1.4	0.9	0.8	068-2003
O1	0.9	0.5	0.5	3.1	1.7	1.6	068-2010
O2	1.3	0.7	0.7	4.5	2.4	2.3	068-2015
O3	2.3	1.2	1.2	8.0	4.3	4.1	068-2006
O4	3.4	1.8	1.7	11.9	6.3	6.1	068-2007
O5	4.3	2.3	2.2	15.0	7.9	7.7	068-2008
O6	5.2	2.8	2.7	18.3	9.7	9.4	068-2009

Capacities based on the following;

R134a = 10 Bar Delta P & Te -5°C

R22 = 14 Bar Delta P & Te -5°C

R404a = 14 Bar Delta P & Te -20°C

Orifice Equivalents

Danfoss	Sporlan	Flica	Alco	Teddington	Egelhof
00	0	0.5/0.7	-	-	0/1
01	1	1/1.5	0	1	2
02	2	2	1	2	3
03	3	2.5	2	3	4
04	4	3	3	4	5/6
05	5	3.5	-	5	-
06	6	4.5	4/5	6	-

Compressor Selections for Domestic Refrigerators

Single Door Refrigerator

Volume			HP	Danfoss		Sicom		L'Unite	
113	to	165	1/12					45008	AZ1320Y
166	to	215	1/10					45020	AZ1330Y
216	to	270	1/8	102G4452	TL4G	48052	TB1345YS	45032	AZ1335Y
271	to	370	1/6	102G4524	TL5FT	48060	THB1355YS	45042	AZ1339Y

Double Door Refrigerator

Volume			HP	Danfoss		Sicom		L'Unite	
226	to	355	1/5	103G6680	FR7.5G	48063	THB1365YS	45186	AE1365Y
356	to	495	1/4	103G6780	FR8.5	48104	TWB1390YS	45198	AE1380Y
496	to	623	1/3	103G6880	FR10G			45342	AE1410Y

Upright & Chest Freezers

Volume			HP	Danfoss		Sicom		L'Unite	
113	to	140	1/6	102G4524	TL5FT	48060	THB1355YS	45042	AZ1339Y
141	to	240	1/5	103G6680	FR7.5G	48063	THB1365YS	45186	AE1365Y
241	to	355	1/4	103G6780	FR8.5	48104	TWB1390YS	45198	AE1380Y
256	to	515	1/3		NL11F	48128	TP1413YS	45342	AE1410Y

Danfoss Service Thermostats

- PROVIDING BENEFITS TO ALL...

The Wholesaler

- Bar coded
- Logical numbering systems
- Easy stock control!

The Installer

- Only 8 different kits
- Satisfies most applications
- Contains *all* necessary mounting accessories
- No time wasted!
- All marked with kit number (1-8)
- All colour coded by application
- NEW ADAPTOR fits both 6.3 mm and 4.8 mm

End user

- Materials designed for recycling
- No CFC
- Environmentally friendly



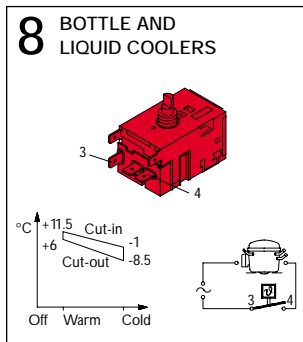
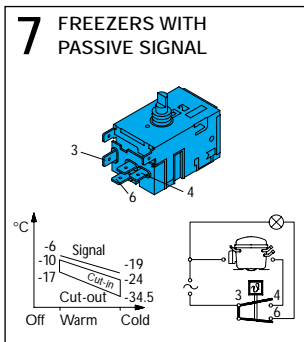
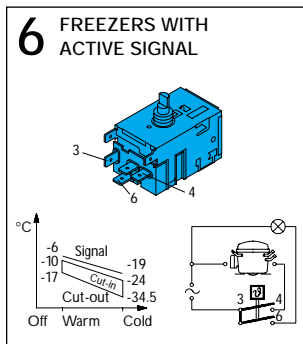
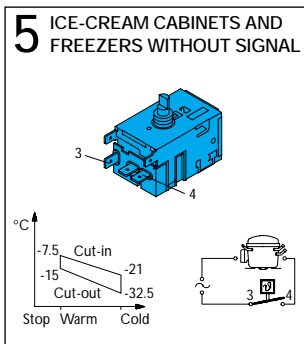
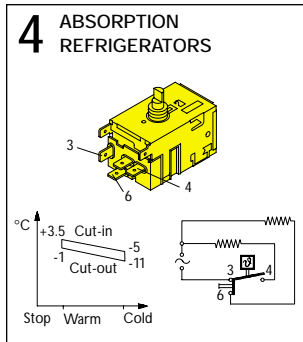
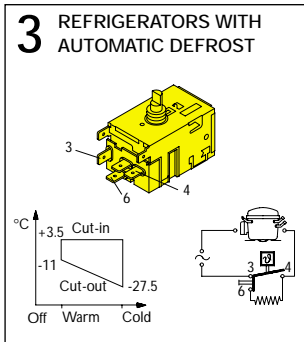
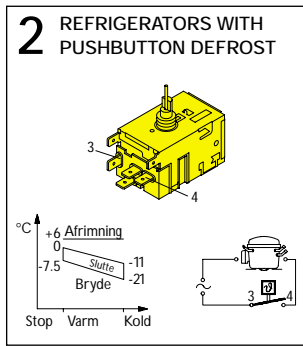
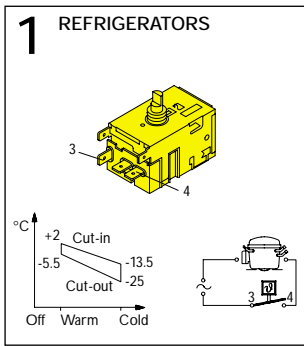

Danfoss Service Thermostats

CONVERSION TABLE



Danfoss Service Thermostats

CONVERSION TABLE

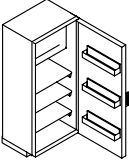
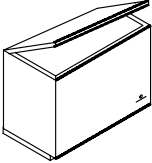
	Danfoss	Atea	Cutler Hammer	Fanal	General Electric	Ranco	Robertshaw	Thomson Houston	Penn	Matsushita	Saginomiya	Pacific Controls	Danfoss Code no.
	090B0 077B0	M2 N2 A01	9530 9533	TF57N/c TF576N FS1	3ART49R 3ART5	A10/VC1 A50/VK1 K50	RC31 RC-1	T5 TB05	TF7	A-1-270	ARB/ATB	PFN	1 077B7001
	090B4	S2				F50/VP4 K60	RC-0	T4 TB04	TF8	A-3-8000	CRB	PFR	2 077B7002
	090B6 077B6 090B62 077B62 077B64	C2 C3 C19 C28	9351 9536	TF57 TF576K FS3	3ART6 3ART29	A59/VT9 K59/VK9	RC35 RC-2 RC-9	T6 TB06 T8 TB08	TF6	A-2-3600	DRB	PFC	3 077B7003
	090B12 077B02	A11	9535	TF57N/a T576N FS4	ART32	A13/VA2 K57	RC-6	TB58					4 077B7004
	090B0 077B0 090B5 077B045	M2 N2	9330 9533	TF57N/e TF57N/d FS5	3ART49R 3ART5 3ART21	A10/VF3 A50 K50	RC31 RC34-1 RC-5	T5 TB05 T0 TB00				PFN	5 077B7005
	090B10 077B20	L3C L3A		TF57S/a FS6	3ART32 3ART7	A54/VS5 A63 K54 K59	RC5	T7 TB71 TB07		A-7-8400			6 077B7006
	090B10 077B30	L3C L3A		TF57S/a	3ART32 3ART7	A54/VR6 A63 K54 K59	RC5	T7 TB71 TB07		A-7-8400			7 077B7007
	090B0 077B0			FS8		VB7							8 077B7008

Metric /Imperial Conversions

Length	1 Inch	25.4 mm	1 mm	0.0394	Inch
	1 ft	304.8 mm	1 mm	0.0033	ft
	1 ft	0.3048 m	1 m	3.2808	ft
	1 mile	1.609 km	1 km	0.6215	mile

Mass	1 grain	0.648 g	1 g	1.543	grain
	1 oz	28.35 g	1 g	0.035	oz
	1 lb	454 g	1 g	0.002	lb
	1 lb	0.454 kg	1 kg	2.203	lb
	1 ton	1.016 tonne	1 tonne	0.984	ton

Area	1 in ²	645 mm ²	1 mm ²	0.00155	in ²
	1 ft ²	0.0929 m ²	1 m ²	10.76	ft ²
	1 acre	0.405 ha	1 ha	2.47	acre

Volume (Solids)	1 in ³	16387 mm ³	1 mm ³	0.000061	in ³
	1 ft ³	0.0283 m ³	1 m ³	35.3	ft ³
	1 yd ³	0.765 m ³	1 m ³	1.31	yd ³

Volume (Liquids & Gasses)	1 fl oz	28.4 ml	1 ml	0.035211	fl oz
	1 pint	568 ml	1 ml	0.0018	pint
	1 pint	0.568 l	1 l	1.76	pint
	1 imp. Gal	4.55 l	1 l	0.220	imp. Gal
	1 US Gal	3.785 l	1 l	0.264	US Gal
	1 imp. Gal	1.2 US Gal	1 US Gal	0.833	imp. Gal

Velocity	1 ft/sec	0.3048 m/s	1 m/s	3.280840	ft/sec
	1 fpm	0.00508 m/s	1 m/s	196.9	fpm
	1 mph	1.61 km/h	1 km/h	0.621118	mph

Pressure	1 psi	6.89 kPa	1 kPa	0.145	psi
	1 lb/ft	47.9 Pa	1 Pa	0.021	lb/ft
	1 in H ₂ O	249 Pa	1 Pa	0.004	in H ₂ O
	1 ft H ₂ O	2.99 kPa	1 kPa	0.334	ft H ₂ O
	1 mm H ₂ O	9.81 Pa	1 Pa	0.102	mm H ₂ O
	1 m H ₂ O	9.81 kPa	1 kPa	0.102	m H ₂ O
	1 in HG	3.39 Pa	1 Pa	0.295	in HG
	1 mm HG	133.3 Pa	1 Pa	0.007502	mm HG
	1 Standard Atmosphere	101.3 kPa	1 kPa	0.0099	Standard Atmosphere
	1 bar	100 kPa	1 kPa	0.010	bar

Temperature	$^{\circ}\text{C} = (^{\circ}\text{F} - 32) \times 5/9$
	$^{\circ}\text{F} = ^{\circ}\text{C} \times 5/9 + 32$
	$\text{K} = ^{\circ}\text{C} + 273$

Power	1 Horsepower	746 watts	1 Kw	1.340	Horsepower
	1 B.t.u./hour	0.293 watts	1 Kw	3413	B.t.u./hour
	1 k.cal/hour	1.163 watts	1 watts	0.860	k.cal/hour
	1 MJ/hour	278 watts	1 Kw	3.6	MJ/hour
	1 ton refrig.	3.52 Kw	1 Kw	0.284	ton refrig.

Fraction Conversions

Fraction	Decimal Inches	Metric mm	Fraction	Decimal Inches	Metric mm
1/64	0.01563	0.39688	33/64	0.51563	13.0969
1/32	0.03125	0.79375	17/32	0.53125	13.4938
3/64	0.04688	1.19063	35/64	0.54688	13.8906
1/16	0.0625	1.5875	9/16	0.5625	14.2875
5/64	0.07813	1.98438	37/64	0.57813	14.6844
3/32	0.09375	2.38125	19/32	0.59375	15.0813
7/64	0.10938	2.77813	39/64	0.60938	15.4781
1/8	0.125	3.175	5/8	0.625	15.875
9/64	0.14063	3.57188	41/64	0.64063	16.2719
5/32	0.15625	3.96875	21/32	0.65625	16.6688
11/64	0.17188	4.36563	43/64	0.67188	17.0656
3/16	0.1875	4.7625	11/16	0.6875	17.4625
13/64	0.20313	5.15938	45/64	0.70313	17.8594
7/32	0.21875	5.55625	23/32	0.71875	18.2563
15/64	0.23438	5.95313	47/64	0.73438	18.6531
1/4	0.25	6.35	3/4	0.75	19.05
17/64	0.26563	6.74688	49/64	0.76563	19.4469
9/32	0.28125	7.14375	25/32	0.78125	19.8438
19/64	0.29688	7.54063	51/64	0.79688	20.2406
5/16	0.3125	7.9375	13/16	0.8125	20.6375
21/64	0.32813	8.33438	53/64	0.82813	21.0344
11/32	0.34375	8.73125	27/32	0.84375	21.4313
23/64	0.35938	9.12813	55/64	0.85938	21.8281
3/8	0.375	9.525	7/8	0.875	22.225
25/64	0.39063	9.92188	57/64	0.89063	22.6219
13/32	0.40625	10.3188	29/32	0.90625	23.0188
27/64	0.42188	10.7156	59/64	0.92188	23.4156
7/16	0.4375	11.1125	15/16	0.9375	23.8125
29/64	0.45313	11.5094	61/64	0.95313	24.2094
15/32	0.46875	11.9063	31/32	0.96875	24.6063
31/64	0.48438	12.3031	63/64	0.98438	25.0031
1/2	0.5	12.7	1	1	25.4

Temperature Quick Convert

Celsius	C or F	Fahrenheit	Celsius	C or F	Fahrenheit	Celsius	C or F	Fahrenheit	Celsius	C or F	Fahrenheit
-40.0	-40	-40.0	-6.7	20	68.0	26.7	80	176.0	60.0	140	284.0
-39.4	-39	-38.2	-6.1	21	69.8	27.2	81	177.8	60.6	141	285.8
-38.9	-38	-36.4	-5.6	22	71.6	27.8	82	179.6	61.1	142	287.6
-38.3	-37	-34.6	-5.0	23	73.4	28.3	83	181.4	61.7	143	289.4
-37.8	-36	-32.8	-4.4	24	75.2	28.9	84	183.2	62.2	144	291.2
-37.2	-35	-31.0	-3.9	25	77.0	29.4	85	185.0	62.8	145	293.0
-36.7	-34	-29.2	-3.3	26	78.8	30.0	86	186.8	63.3	146	294.8
-36.1	-33	-27.4	-2.8	27	80.6	30.6	87	188.6	63.9	147	296.6
-35.6	-32	-25.6	-2.2	28	82.4	31.1	88	190.4	64.4	148	298.4
-35.0	-31	-23.8	-1.7	29	84.2	31.7	89	192.2	65.0	149	300.2
-34.4	-30	-22.0	-1.1	30	86.0	32.2	90	194.0	65.6	150	302.0
-33.9	-29	-20.2	-0.6	31	87.8	32.8	91	195.8	66.1	151	303.8
-33.3	-28	-18.4	0.0	32	89.6	33.3	92	197.6	66.7	152	305.6
-32.8	-27	-16.6	0.6	33	91.4	33.9	93	199.4	67.2	153	307.4
-32.2	-26	-14.8	1.1	34	93.2	34.4	94	201.2	67.8	154	309.2
-31.7	-25	-13.0	1.7	35	95.0	35.0	95	203.0	68.3	155	311.0
-31.1	-24	-11.2	2.2	36	96.8	35.6	96	204.8	68.9	156	312.8
-30.6	-23	-9.4	2.8	37	98.6	36.1	97	206.6	69.4	157	314.6
-30.0	-22	-7.6	3.3	38	100.4	36.7	98	208.4	70.0	158	316.4
-29.4	-21	-5.8	3.9	39	102.2	37.2	99	210.2	70.6	159	318.2
-28.9	-20	-4.0	4.4	40	104.0	37.8	100	212.0	71.1	160	320.0
-28.3	-19	-2.2	5.0	41	105.8	38.3	101	213.8	71.7	161	321.8
-27.8	-18	-0.4	5.6	42	107.6	38.9	102	215.6	72.2	162	323.6
-27.2	-17	1.4	6.1	43	109.4	39.4	103	217.4	72.8	163	325.4
-26.7	-16	3.2	6.7	44	111.2	40.0	104	219.2	73.3	164	327.2
-26.1	-15	5.0	7.2	45	113.0	40.6	105	221.0	73.9	165	329.0
-25.6	-14	6.8	7.8	46	114.8	41.1	106	222.8	74.4	166	330.8
-25.0	-13	8.6	8.3	47	116.6	41.7	107	224.6	75.0	167	332.6
-24.4	-12	10.4	8.9	48	118.4	42.2	108	226.4	75.6	168	334.4
-23.9	-11	12.2	9.4	49	120.2	42.8	109	228.2	76.1	169	336.2
-23.3	-10	14.0	10.0	50	122.0	43.3	110	230.0	76.7	170	338.0
-22.8	-9	15.8	10.6	51	123.8	43.9	111	231.8	77.2	171	339.8
-22.2	-8	17.6	11.1	52	125.6	44.4	112	233.6	77.8	172	341.6
-21.7	-7	19.4	11.7	53	127.4	45.0	113	235.4	78.3	173	343.4
-21.1	-6	21.2	12.2	54	129.2	45.6	114	237.2	78.9	174	345.2
-20.6	-5	23.0	12.8	55	131.0	46.1	115	239.0	79.4	175	347.0
-20.0	-4	24.8	13.3	56	132.8	46.7	116	240.8	80.0	176	348.8
-19.4	-3	26.6	13.9	57	134.6	47.2	117	242.6	80.6	177	350.6
-18.9	-2	28.4	14.4	58	136.4	47.8	118	244.4	81.1	178	352.4
-18.3	-1	30.2	15.0	59	138.2	48.3	119	246.2	81.7	179	354.2
-17.8	0	32.0	15.6	60	140.0	48.9	120	248.0	82.2	180	356.0
-17.2	1	33.8	16.1	61	141.8	49.4	121	249.8	82.8	181	357.8
-16.7	2	35.6	16.7	62	143.6	50.0	122	251.6	83.3	182	359.6
-16.1	3	37.4	17.2	63	145.4	50.6	123	253.4	83.9	183	361.4
-15.6	4	39.2	17.8	64	147.2	51.1	124	255.2	84.4	184	363.2
-15.0	5	41.0	18.3	65	149.0	51.7	125	257.0	85.0	185	365.0
-14.4	6	42.8	18.9	66	150.8	52.2	126	258.8	85.6	186	366.8
-13.9	7	44.6	19.4	67	152.6	52.8	127	260.6	86.1	187	368.6
-13.3	8	46.4	20.0	68	154.4	53.3	128	262.4	86.7	188	370.4
-12.8	9	48.2	20.6	69	156.2	53.9	129	264.2	87.2	189	372.2
-12.2	10	50.0	21.1	70	158.0	54.4	130	266.0	87.8	190	374.0
-11.7	11	51.8	21.7	71	159.8	55.0	131	267.8	88.3	191	375.8
-11.1	12	53.6	22.2	72	161.6	55.6	132	269.6	88.9	192	377.6
-10.6	13	55.4	22.8	73	163.4	56.1	133	271.4	89.4	193	379.4
-10.0	14	57.2	23.3	74	165.2	56.7	134	273.2	90.0	194	381.2
-9.4	15	59.0	23.9	75	167.0	57.2	135	275.0	90.6	195	383.0
-8.9	16	60.8	24.4	76	168.8	57.8	136	276.8	91.1	196	384.8
-8.3	17	62.6	25.0	77	170.6	58.3	137	278.6	91.7	197	386.6
-7.8	18	64.4	25.6	78	172.4	58.9	138	280.4	92.2	198	388.4
-7.2	19	66.2	26.1	79	174.2	59.4	139	282.2	92.8	199	390.2

Refrigerants Cross Reference Guide

ASHRAE#	Tradenames	Manufacturers	Type	Lubricant	Evaporator Temperature			Applications
					High	Med	Low	
R-12 Replacements								
R-134a	Suva® 134a Genetron® 134a Forane® 134a Klea® 134a	DuPont Honeywell Atofina ICI	HFC	POE	X	X		Commercial refrigeration Appliances Chillers Automotive A/C: new & retrofit
R-401A	Suva® MP39 Genetron® MP39	DuPont Honeywell	HCFC	MO or AB	X	X		Positive displacement refrigeration equipment Supermarket systems: medium temp Walk-in coolers
R-409A	Suva® 409A Genetron® 409A Forane® 409A	DuPont Honeywell Atofina	HCFC	MO or AB	X	X		Positive displacement refrigeration equipment Supermarket systems: medium temp Walk-in coolers
R-500 Replacements								
R-401B	Suva® MP66 Genetron® MP66	DuPont Honeywell	HCFC	MO or AB		X	X	Closest performance match to R-500 Best retrofit choice for R-12 freezers R-12 transport refrigeration equipment
R-502 Replacements								
R-404A	Suva® HP62 Genetron® 404A Forane® 404A	DuPont Honeywell Atofina	HFC	POE	X	X	X	New equipment & retrofit for commercial refrigeration R-502 transport refrigeration
R-507	Suva® 507 Genetron® AZ50 Forane® 507	DuPont Honeywell Atofina	HFC	POE	X	X	X	New equipment & retrofit for commercial refrigeration R-502 transport refrigeration
R-408A	Suva® 408A Genetron® 408A Forane® 408A	DuPont Honeywell Atofina	HCFC	MO or AB	X	X	X	Existing commercial refrigeration equipment
R-402A	Suva® HP80 Genetron® HP80	DuPont Honeywell	HCFC	MO or AB	X	X	X	Existing commercial refrigeration equipment
R-402B	Suva® HP81 Genetron® HP81	DuPont Honeywell	HCFC	MO or AB		X	X	Ice machines and other selected applications
R-22 Replacements								
R-407C	Suva® 407C Genetron® 407C Forane® 407C Klea 407C	DuPont Honeywell Atofina ICI	HFC	POE	X			Positive displacement A/C equipment New commercial and light commercial A/C. Existing residential and commercial/ light commercial A/C - always consult the OEM for guidance.
R-410A	Suva® 410A Puron® Genetron® 410A Forane® 410A	DuPont Carrier Honeywell Atofina	HFC	POE	X			Positive displacement A/C - NEW residential & commercial A/C & heat pumps designed for R-410A. May be used in some existing R-22 A/C systems, but extensive changes required - always consult the OEM.
R-13, R-23, R-503 Replacements								
R-508B	Suva® 95 Genetron® 508B	DuPont Honeywell	PFC	POE	Below -40°F			New & existing VLT (below -40°F) applications Cascade refrigeration systems
R-11 Replacements								
R-123	Suva® 123 Genetron® 123 Forane® 123	DuPont Honeywell Atofina	HCFC	MO	X	X		New and existing centrifugal chillers (consult OEM)
R-114 Replacements								
R-124	Suva® 124 Genetron® 124 Forane® 124	DuPont Honeywell Atofina	HCFC	AB	X	X		Industrial refrigeration & A/C High ambient A/C

Footnotes: • Suva® HFC refrigerants: (1) long-term replacements, (2) zero ozone depletion, (3) no phase-out date
• ALL Suva® refrigerants are UL classified
• ALL Suva® refrigerants have A1 ASHRAE Safety Classification, except Suva® 123 which has a B1 ASHRAE Safety Classification.

AB = Alkylbenzene
MO = Mineral Oil
POE = Polyol Ester

CALL US: 800-235-SUVA
VISIT US: WWW.SUVA.DUPONT.COM



The miracles of science®

Service Tips

1	Oil Recommendation	Refer to OEM or compressor guidelines. If not available, refer to Lubricant recommendation on Chart.
2	Handling POE	<ul style="list-style-type: none"> • Keep POE containers closed • Minimize the time systems are open—install caps in lines until they are sealed • Keep system clean and dry • When brazing, purge lines with dry nitrogen • Evacuate system thoroughly—500 mm Hg vacuum
3	Topping Off The Charge	Suva® refrigerants can be topped off after a leak. The original charge does NOT have to be removed.
4	Refrigerant Charging	Remove liquid only from the charging cylinder. The proper cylinder position for liquid removal is indicated by arrows on the cylinder and cylinder box.
5	Mixing Refrigerants	DO NOT mix refrigerants with different “R” numbers. Uncertain performance or damage could result.
6	Which Suva® Refrigerants Can Be Used Without An Oil Change?	Field experience has shown that Suva® MP39, 409A, MP66, 408A, HP80, and HP81 work successfully with the existing MO in many unitary and other close-coupled systems. Insure that the system will provide good oil return to the compressor before retrofitting without an oil change. Note: Many replacement compressors already contain AB lubricant, therefore, no oil change is required when converting to an HCFC.
7	HFC Leak Detection	<ul style="list-style-type: none"> • HFCs are harder to detect than CFCs and HCFCs. • Detector must be calibrated correctly—consult your leak detector supplier

If Customer Asks for...

Offer Them This...

Tradenames	ASHRAE#	Manufacturer	DUPONT Refrigerant
Isceon® R69L	R-403B	Rhodia	Suva® 408A, HP80
	R-406A		Suva® 409A, MP39
Klea® 60	R-407A	ICI	Suva® HP62, 507
Klea® 61	R-407B	ICI	Suva® HP62, 507
Klea® 5R3	R-508A	ICI	Suva® 95
Puron® Genetron® AZ-20 Forane® 410A	R-410A	Carrier Honeywell Atofina	Suva® 410A
Greencool 2018A	R-411A	Greencool	Suva® 408A, HP80
Greencool 2018B	R-411B	Greencool	Suva® 408A, HP80
Arcton® TP5R	R-412A	ICI	Suva® 408A, HP80
Hot Shot™	R-414B	ICOR International	Suva® 409A, MP39 (use R134a for Auto A/C)
FRIGC® FR-12	R-416A	Intercool Distribution, LLC	Suva® 409A, MP39 (use R134a for Auto A/C)
Freezone™ RB276	—	—	Suva® 409A, MP39 (use R134a for Auto A/C)
NU-22 Isceon® 59	R-417A	ICOR International Rhodia	Freon® 22, Suva® 407C (above 20°F evap temp; a/c), Suva® 404A, 507 (below 20°F)

What to Expect After Retrofit

Suva® Refrigerant	Discharge Pressure (psi)	Suction Pressure (psi)	Discharge Temperature (°F)	Refrigeration Capacity (%)	Expected Superheat (°F)
134a	+20	-2	-10	-10	-4
MP39	+20	Same	+25	+10	-3
MP66	+30	+2	+30	+15	-1
409A	+25	Same	+30	+10	-4
HP80	+40	+5	-5	+15	+4
HP81	+30	+5	+15	+15	Same
408A	+5	Same	+20	+5	-3
HP62	+20	Same	-10	Same	+2
507	+30	Same	-15	Same	+4
407C	+15	Same	-15	Same	+1
95	+2	Same	-40	-2	Same

Suva® HP62, 408A, HP80, 507, and HP81 are compared to R502.

Suva® 407C is compared to R-22.

Suva® MP39, 409A, MP66, and R-134a are compared to R12.

Suva® 95 is compared to R-503.

+ is increase - is decrease This information is intended to serve as a guide; the actual performance may vary.



The miracles of science®